

FIG. DC-700:

WAFER STYLE DUAL DOOR CHECK VALVE



Features:

- General Design: ANSI Class 125 (EN 12334) & API 594 Working Pressure: ASME B16.34 (EN 12334)
- Flange mate: ANSI B16.1 & B16.5
- Face to face: ISO 5752-82
- Valve Testing: API 598

Materials List:

No.	Part Name	Specification
1	Body	A126B Cast Iron
		A536 Ductile Iron
2	Seat	NBR, EPDM, Viton
3	Disc	A536 Ductile Iron
		CF8M
4	Spring	A276 431SS
5	Stem	416SS / 316SS

Note:

Working Temperature: -10° C to 150° C.

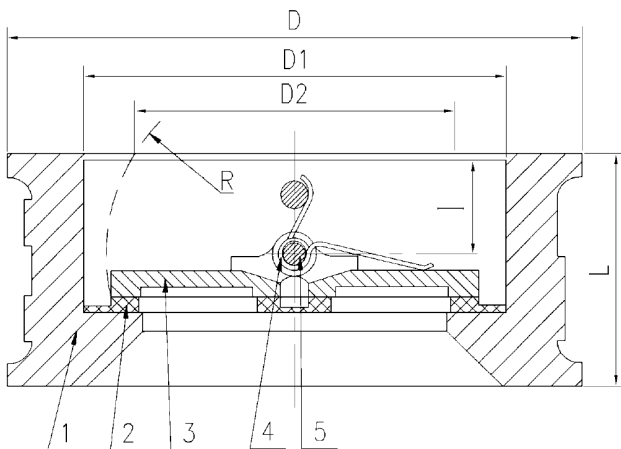

Dimensions:

Size		D		D1		D2		L		R		I		Weight	
in	mm	in	mm	in	mm	in	mm	in	mm	in	mm	in	mm	lbs	kgs
2	50	4.20	107	2.56	65	1.70	43.30	1.69	43	1.13	28.80	0.75	19	3.30	1.50
2 ½	65	5.00	127	3.15	80	2.37	60.20	1.81	46	1.13	28.80	0.79	20	5.28	2.40
3	80	5.59	142	3.70	94	2.61	66.40	2.53	64	1.42	36.10	1.10	28	7.92	3.60
4	100	6.38	162	4.60	117	3.57	90.80	2.53	64	1.7	43.40	1.06	27	12.54	5.70
5	125	7.56	192	5.70	145	4.60	116.90	2.76	70	2.00	52.60	1.18	30	16.00	7.30
6	150	8.58	218	6.70	170	5.69	144.60	2.99	76	2.59	65.70	1.22	31	19.80	9.00
8	200	10.75	273	8.80	224	7.80	198.20	3.50	89	3.09	78.60	1.30	33	37.40	17.00
10	250	12.91	328	10.40	265	9.20	233.70	4.49	114	4.11	104.40	1.97	50	57.20	26.00
12	300	14.88	378	12.20	310	10.98	279.00	4.49	114	5.00	127.00	1.69	43	81.40	37.00
14	350	17.24	438	14.20	360	12.91	327.00	5.00	127	5.83	148.00	1.77	45	120.80	54.90
16	400	19.25	489	16.00	410	14.80	375.00	5.50	140	6.79	172.00	2.04	52	171.60	78.00
18	450	21.85	555	17.70	450	16.30	414.00	5.98	152	7.77	197.00	2.28	58	261.80	119.00
20	500	23.39	594	19.90	505	18.15	468.00	5.98	152	8.57	218.00	2.28	58	268.00	122.00
24	600	27.56	700	24.60	624	22.42	570.00	7.00	178	9.49	241.00	0.12	3	383.00	174.00